

BODY SPECIFICATION SHEET

SUPER STOCK ELIMINATOR CLASSES

MAKE: _____ MODEL: _____ YEAR: _____ CLASS: _____

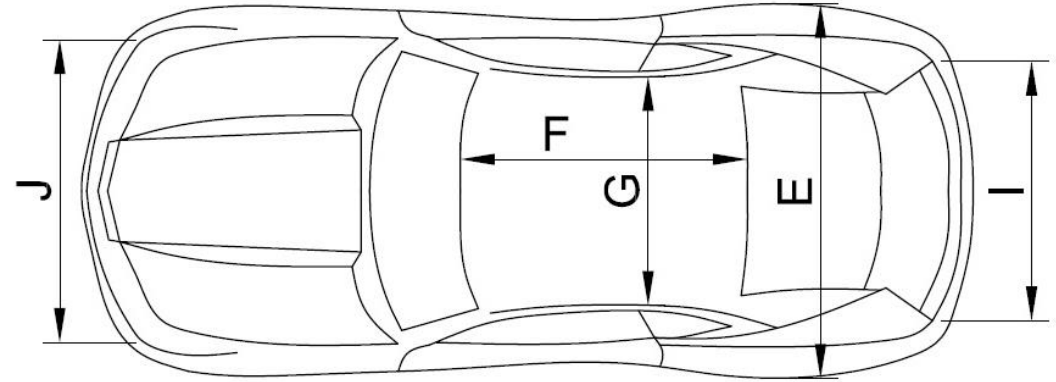
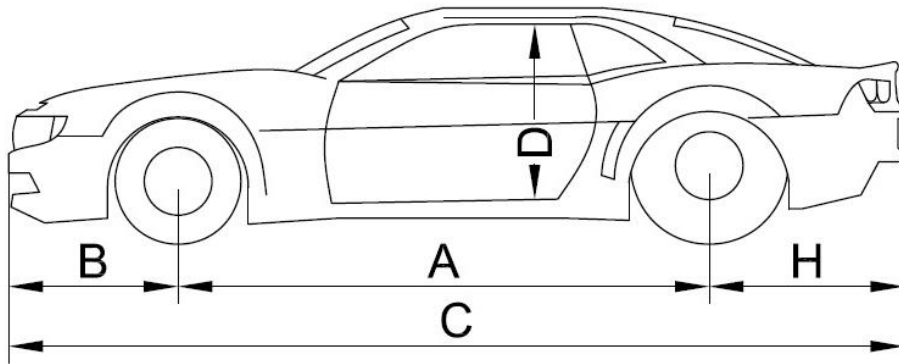

DETAILS	A Wheelbase	B Front Overhang	C Body Length	D Door Height	E Body Width	F Roof Length	G Roof Width	H Rear Overhang	I Rear Width - tail lights	J Front Width - headlights
STANDARD DIMENSION										
PROPOSED DIMENSION										

Read other side of form or page attached for instructions on measurements required.

VEHICLE OWNER DETAILS AND DECLARATION

I understand that if any of the above information is found to be incorrect, I render myself liable to Tribunal Action.

NAME: _____ LICENCE/MEMBERSHIP No. _____ SIGNATURE _____.

BODY SPECIFICATION SHEET

The onus of proof is on the competitor to substantiate the declared model of vehicle. All standard required dimensions along with the competing vehicles dimensions must be provided. The five basic measurements required for declaration as a Super Stock / Gas or Altered Production vehicle are outlined below. In all cases refer to class regulations in Rulebook for further details.

a) Overall Wheelbase.

Super Stock / Gas: This measurement must be within 2 inches (51mm) of the standard measurement for the declared model, and any variation from left to right must be within the 1-inch (25mm) tolerance. For details refer to Body Regulations

Altered Production: 2921mm (115 inch) maximum, or standard wheelbase for body used where longer.

b) Front Overhang.

Super Stock: Measured from the forward most wheel to the forward most point of the vehicle, this measurement must not exceed 1 inch (25.4mm) over standard measurements for the declared model.

Altered Production: Refer to Body Regulations.

c) Overall Body Length.

Super Stock: This measurement must be within standard measurements for the declared model. A tolerance of + or - 1 inch (25.4mm) is permitted. In the case of vehicles relocating axle position, the addition of up to 4 inches (101.6mm) may be added to the total length of the vehicle.

Altered Production: Refer to Body Regulations.

d) Overall Height.

Super Stock: This measurement must be within standard measurements for the declared model, with a tolerance of + or - 10mm permitted. The measurement is to be taken from the bottom of the door-jam to the top of the door cavity (drip rail in most instances) at the rear of the front door.

Altered Production: Refer to Body Regulations.

e) Overall Width.

Super Stock: This measurement must be within standard measurements for the declared model, with a tolerance of + or - 1 inch (25.4mm) permitted. The measurement is to be taken at "door locks" level at the widest point of the vehicle, using the same point on both sides of the vehicle.

Altered Production: Refer to Body Regulations.

f & g) Roof Length & Width.

These measurements are taken across the roof with a straight edge. DO NOT follow the contour of the roof.

h) Rear Overhang.

Measured from the rear axle centreline to the rear of the vehicle, NOT including parachute packs. Must include the rear bumper bar.

i & j) Front & Rear Width.

These measurements are taken from the outside point of the tail and headlights with a straight edge. No classes, unless stated, permit wedging or narrowing or any type.

All body dimensions should be forwarded to the **Technical Officer** at ANDRA Head Office.